



PHOTOS MAY SHOW OPTIONAL OR CUSTOMISED EQUIPMENT.

LINE TYPESBasic Line
(Continuous)Basic Line
(Interrupted)**THERMOPLASTIC SPRAY PLASTIC APPLICATION (PUMP)**

The Borum® Master 3000 series provides you with a variety of high capacity line marking machines designed for large scale jobs such as marking highways, motorways or airport runways.

The material tank capacity can be up to 445L. The possibility for the large material capacity naturally gives fewer stops during the day for refilling.

The BM 3000 has a two-seat slidable drive and operator section for flexible working on left or right side.

The Borum spray plastic equipment can apply lines of up to 60 cm width, depending on the set-up. The equipment may be used for the application of plain lines, single and double lines of different widths, as well as for simultaneous application of continuous and interrupted lines.

KNOWING THE BM 3000

OPERATOR SECTION

Quick and easy change from side to side for marking left and right. Dual torque steering - good directional stability. Cruise control can be added as

LINEMASTER COMPUTER

With the LineMaster Computer you can control up to 6 paint or spray guns, 6 bead guns and equipment with up to 24 shutters. Moreover, it controls all these various sets of equipment in this

FULL REAR VIEW

DIESEL TANKS

Allows for a full day's work without refuelling.

ENGINE ROOM

Easy access for service.

PRESSURIZED BEAD TANK

Tank divided in two separate tanks. Individual or single outlet.

CHASSIS

Solid double-frame construction

MATERIAL TANKS

The possibility of an extra large material tank for major works ensures the most efficient workday and fast progression of the road works. Combination of hot thermoplastic and cold paint is also possible on an extended chassis.

WHEEL MOTOR

2-speed wheel motor
Allows working uphill

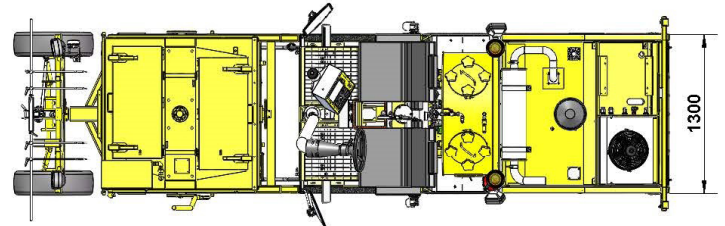
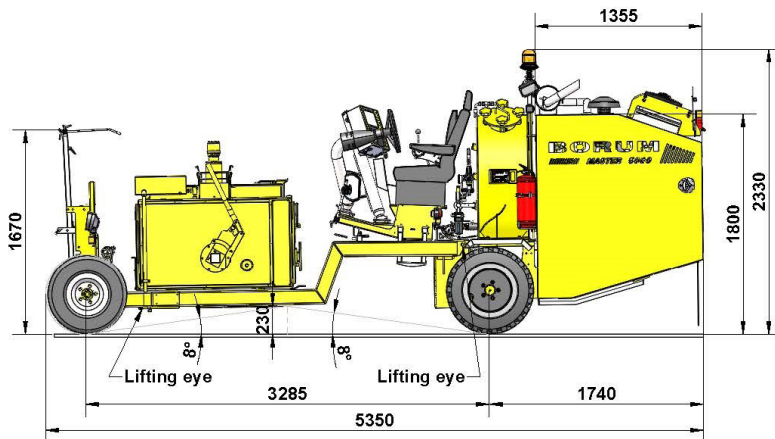

TECHNICAL SPECIFICATIONS

ENGINE	
Manufacturer	Kubota
Type	Turbo
Cooling	Water
Cylinder	4 stroke 3600 cm ³
RatedPower	63 KW
Approval	EU Stage IIIA resp. TIER 3
COMPRESSOR	
Compressor Capacity	Choice of 1-2 compressors can give 1800 - 3600 L/min @ 10 bar. Integrated oil-cooling system. Air-cooler incl. water separator
FILLING CAPACITIES	
Fuel tank capacity	180 L (2 x 90 L)
Hydraulic tank size	93 L
Bead capacity	330 L (2 x 165 L). Pressurised (max 3 bars)
MATERIAL TANK	
Material Tank	445 L
DRIVING PROPERTIES	
Drive angle	10.4 degrees / 18% (5000 kg)
Turning radius	4.90 m.
Steering	Dual torque steering
TRANSMISSION	
Hydrostatic transmission	For variable speed
Speed	0-22 km/h
ELECTRICAL SYSTEM	
Electrical system	12 V / 130 Amp
CONTROL UNIT	
Borum LineMaster	Program up to 99 different line types. Organise lines in up to 30 marking programs. 8" display. Transfer of daily marking reports. See more detailed info.
COLOUR	
Colour	RAL 1007 (Other colours available on request)
DIMENSIONS	
Length	5350 mm
Width	1300 mm
Height	2250 mm

THERMO SPRAY APPLICATION (PUMP)

The thermoplastic spray application equipment works via a pump. The amount of the applied material is set by the pressure of the pump and the air pressure of spraying, but the pump can also be adjusted to the speed of the machine.



SPRAY-PLASTIC PUMP

Spray-plastic pump operates with a non-pressurised material tank. The pump consists of a hydraulically driven motor, gearbox, clutch, highly durable rotors and pump house. Pump housing is oil-jacketed and isolated. Capacity up to 80 L/min. at 8.5 bar (21 gal/min. at 123 psi).

The hydraulic control valve adjusts the quantity of spray-plastic material according to the speed of the machine in order to obtain a constant layer thickness.

The application speed can go up to 15 km/h.

Hydraulic transmission with motor, shaft, safety valve and on/off valve.

Sliding retainer frame, on which 1-3 spray guns and 1-3 bead guns are attached. Easily slideable from side to side for an optimal working position. Ground distance is maintained by retainer wheels to ensure a constant road marking width. All material pipes are oil-jacketed and insulated to maintain an ideal material temperature. Lifting of retainer from operators seat using a hydraulic cylinder.

Automatic high-capacity spray plastic gun. Consists of an oil jacketed gun body and a pneumatic cylinder.

BM SP 2500 SPRAY-PLASTIC GUN

Automatic high-capacity spray plastic gun. Consists of an oil jacketed gun body and a pneumatic cylinder. Possibility to apply line widths ranging from 10 - 20 cm depending on line thickness, work conditions, application speed and layer thickness. As an alternative, we offer a narrow nozzle, which can spray 5-15 cm with one gun.

Optional narrow nozzle size of 3 mm or wide nozzle size of 7 mm.

NON-PRESSURISED THERMOPLASTIC TANK

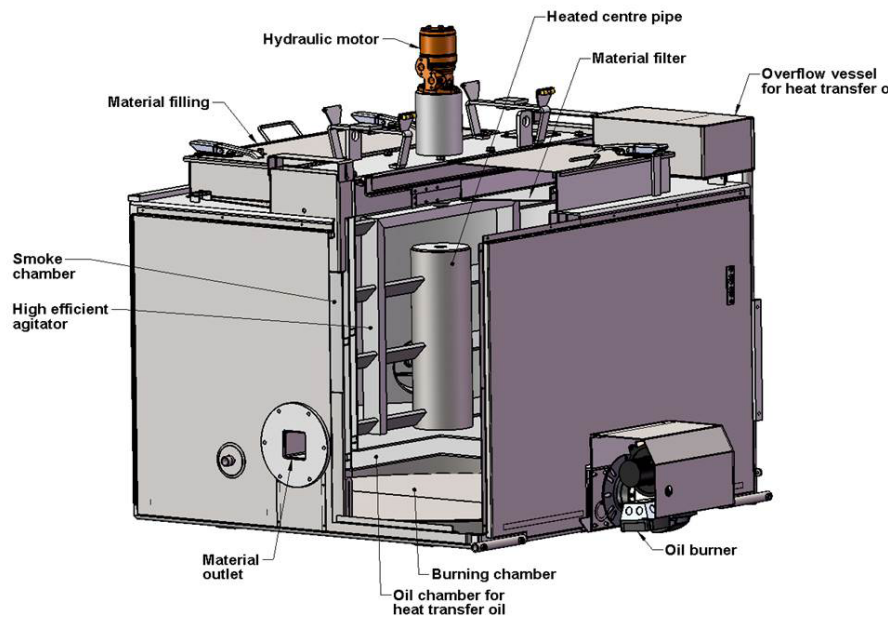

THERMOPLASTIC NON-PRESSURIZED TANK:

Non-pressurized thermoplastic tank indirectly heated via heat transfer oil. The thermal oil and thermoplastic material temperature is thermostatically controlled and regulated automatically.

BURNER SYSTEM

Diesel burner system for heating of the thermal oil (and thermoplastic). Propane burner available on demand.

VERTICAL AGITATOR (MIXER)

With hydraulic transmission. Heated center pipe for efficient uniform temperature control. Perfect melting & homogenization of the thermoplastic. Stable construction with foundation and bearings at the top of the material tank.

LINEMASTER FEATURES

The Borum LineMaster allows you efficient control of all line marking tasks, from line application and pre-marking to reporting and invoicing. It is possible to store up to 99 different line types, and to arrange these in up to 30 different marking programs. You are also able to pre-set line widths, line types, colours and combinations to have them ready for marking, and can instantly adjust them on the go.

CRUISE CONTROL

For your convenience we recommend use of cruise control. Read more about the cruise control in the Borum Knowledge Lab on www.borum.as.

QUICK CLEANING

Pneumatically controlled quick cleaning system for removal of solids left in the extrusion slot. Can be activated while extrusion is in process and is only slightly detectable on the line in the form of a moderate thickening of layer.

RAW MATERIALS

We recommend using a high quality application material. Please contact your material supplier for further advice on choosing the right material.

The spray plastic application equipment that works with a pump gives you the possibility of quickly adjusting the pressure while driving. Our LineMaster may also to a certain extent do this automatically.

Furthermore, filling and thermoplastic filtration is easy, since the tank lid is larger than the one on the pressurized tank.

Sprayed thermoplastic forms a uniform application that is more durable and dries faster compared to cold paint applications.



TYPICAL USES:

Thermoplastic spray plastic is generally used for road marking in inter-urban areas.



LEARN MORE

Find out more in the Borum Knowledge Lab.

ADDITIONAL EQUIPMENT

The additional equipment can be mounted on the machine according to your requirements. They are not necessary for the running of the machine, but add to the comfort of the machine driver or to the functionality of the machine.



Ejector filling of bead tank



Pointer turning with steering
With hydraulic lifting system



Fixed pointer
With hydraulic lifting system



Cruise control



Sunshade with 1 rotating light



Bead alarm mounted on bead gun



Remote control for BM Lin-eMaster



Cone holder



Bar with pneumatic lift for mounting warning lights
(Comes without lights)



Air drier for bead tank



GPS system



Pre-marking system with paint gun



Airknife



Pre-marking system with paint can



Hydraulic broom